

**A designer's guide  
to the specification of fasteners**



## Introduction to SFS intec

The SFS Group of companies, which has its headquarters in Heerbrugg, Switzerland, is one of the world's leading **developers, manufacturers** and **suppliers** of mechanical fastening systems, high-precision components and system products for a variety of technical industries.

Backed by the extensive resources of a successful international group, SFS intec sales and marketing support locations in Europe, North America, Near-Far East and China, can offer architects, designers, consulting engineers and contractors a proven commitment to product, quality and innovative ideas.

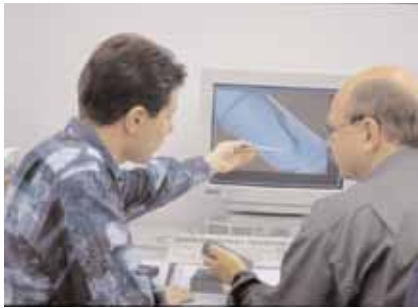

**Developer**

### **Innovative solutions to benefit everyone - from architect through to client.**

As building design moves forward, architects, designers, and contractors face new challenges and new problems - which must be met with innovative product solutions. At SFS intec we aim to meet - and exceed - your expectations of product performance through constant research and development into practical, effective fasteners and air sealing solutions. Through our close relationship with testing institutes, research laboratories and manufacturers of roofing and cladding systems, plus our own in-house research into metallurgy, drill technology and corrosion testing, we are able to bring you the most technologically advanced solutions to today's market needs.



**Manufacturer**

### **SFS intec as a manufacturer.**

A single global total quality management system ensures a uniform quality standard wherever the parts may be produced. Our state-of-the-art production in ten facilities located in Europe and North America focus on producing high quality products and providing continuous availability.



**Supplier**

### **Your local global partner**

With over 20 sales and marketing support locations and a distribution and service network in Europe, North America, Near-Far East and China, SFS intec ensures the continuous availability of products and services.

## SFS intec's comprehensive products and services at a glance

Industrial / pitched roof and siding construction is subject to rapid technical change. Attaching structural components to roofing and siding imposes a wide range of demands: for example, sub-structures of thin cold-formed sections or thick hot rolled steel-sections, tightness, mechanical reliability of the fastening, protection against corrosion and visual (aesthetic) impact. **SFS intec** has made it its business to provide comprehensive services to fulfill all the user's requirements for attaching structural components to roofing and siding using fastening systems with a technological lead.

### Systematic collection of application needs worldwide.

New cost and energy-saving structural elements call for new fastening solutions. Discussions with customers are the starting point for economical and reliable application solutions suitable for use in practice.



### New solutions, implemented rapidly and precisely.

The new solution is produced on schedule in the company's own manufacturing facilities.



### Total customer care.

From establishing requirements to utilization on the job site by competent specialists.



### You can depend on it.

The high quality standards expected of our products and services are guaranteed by fully integrated quality control.

It goes without saying that SFS intec fasteners have been awarded the requisite **approvals** and test certificates by national and **international testing institutions**.



**This trade mark stands for the highest quality!**



## SFS intec's comprehensive products and services at a glance

### **Local availability, fast and reliable.**

The daily goal of our logistics specialists is perfect delivery service to customers from our local stocks, throughout the world.



### **Training on the job site.** We train your personnel on-site.

We guarantee tool service. These ensure the consistency of installation quality and efficiency, right from start up.



### **Customized systems offerings** from a single source.

In order to simplify the completion of projects for customers, we offer them further products in addition to our core competence in fastening technology.



### **Decades of experience, proven millions of times, worldwide.**

Our customers and partners place their confidence in us on the basis of our technological leadership, quality standards and expert applications advice.



<b>Contents</b>		<b>page</b>
<b>Introduction to the principal functions of fasteners</b>		<b>6</b>
<b>Section 1 - Durability</b>		<b>7</b>
1.1	Fastener material	7
1.2	The problem	8
1.3	Types of corrosion	9
1.4	Limitations of coated carbon steel	10
1.5	Types of stainless steel	11
1.5.1	Other types of "stainless" fasteners	12
1.6	Carbon or stainless? Selection considerations	13
1.6.1	System materials	14
1.6.2	Design life requirements	15
1.6.3	External environment	17
1.6.4	Internal environment (building use) / summary	18
1.7	Guide to fastener material selection table	19
1.8	Stainless steel product range	20
<b>Section 2 - Weathertightness</b>		<b>21</b>
2.1	The problem	21
2.2	The SFS solution	22
2.3	Specialist fastener designs	23
<b>Section 3 - Aesthetics</b>		<b>25</b>
3.1	The problem	25
3.2	The SFS solution	26
3.3	Low-profile aesthetic head	26
3.4	Aesthetics with security	26
<b>Section 4 - Structural performance</b>		<b>27</b>
4.1	Structural performance of fasteners	27
4.10	Structural performance of fasteners	27
4.12	Tooling	30
<b>Section 5 - Summary</b>		<b>31</b>
5.1	Solutions to the four principal functions	31
5.2	Model specification sheets	32
5.3	Specification support information - Internet - welcome by SFS intec	33
<b>Section 6 - Project referrals (worldwide)</b>		<b>37</b>

## Introduction

---

The specification of the fastener, despite being such a small component, is critical if the roofing and cladding system is to perform its required function throughout the full term of the system's service and design life. The specification of the fastener needs, therefore, to be addressed at the design stage of a project.

**This guide addresses the four principal functions of fasteners, namely;**

### Durability



### Weathertightness



### Aesthetics



### Structural performance



Each particular application will need the fastener to comply with at least two or three of these functions and often will need all four. Failure of the fastener to satisfy these functions may lead to the inevitable, and sometimes catastrophic, failure of the system or, at the very least, very costly remedial works. This guide will give you the information you need to be able to specify fasteners so as to minimize the risk of roof failure.

## 1.1 - Fastener material

---

Threaded fasteners for roofing and cladding systems are available in the market place in a range of materials, most commonly:

- **Carbon steel (coated)** As carbon steel would rapidly corrode on exposure to humidity, fasteners in this material are supplied with some form of protective coating, typically metallic or organic, or a combination of the two.
- **Stainless steel** For increased durability, fasteners are also supplied in “stainless” steel of various grades. The relative merits of the different grades are discussed later in this guide.
- **Aluminium** Aluminium offers enhanced durability over coated carbon steel, however, due to its softness, it is unable to drill or threadform into steel sheets or supports, and is therefore restricted to securing aluminium sheets to timber supports and some limited applications of aluminium to aluminium.

## 1.2 - The problem

Corrosion of fasteners for roofing and cladding will result in a number of problems and, if allowed to progress, ultimate failure of the system will occur.



Corrosion of fastener head

### Corrosion of the head and washer

- Staining of cladding
- Reduction in pullover performance
- Potential leakage
- Increased maintenance
- Aesthetics

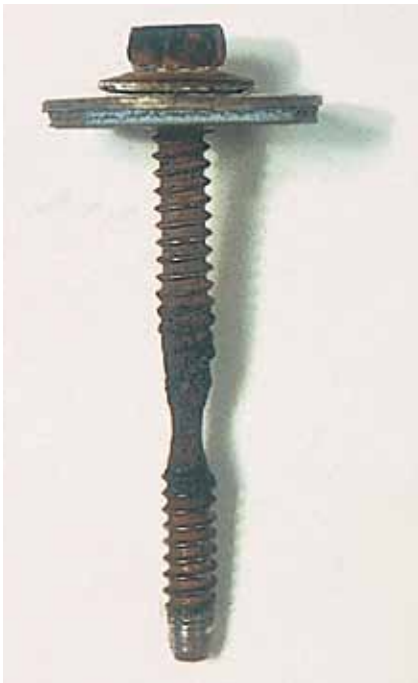

Hidden corrosion of fastener shank

### Corrosion of the shank

- Reduction in tensile performance
- Reduction in shear performance
- Reduction in pullout values
- Staining of interior surfaces
- Safety risk
- Fouling

### Hidden corrosion

- While corrosion of exposed heads on the external face of the building and corrosion of the visible shank inside the building are both easily identified, what is considered a much greater security risk is corrosion of the fastener **within** the roofing and cladding construction. This may only manifest itself upon ultimate failure of the fastener, which would result in partial, and potentially total, detachment of the system

### 1.3 - Types of corrosion

There are many types of corrosion, however the types relevant to (coated) carbon steel fasteners are summarised below.

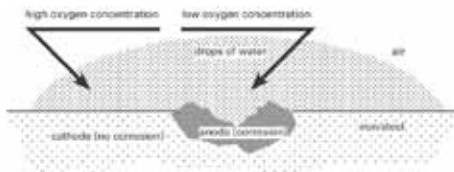

- **Generalized corrosion (oxygen type)**

Plain and low alloy steels containing less than 13% chromium corrode in neutral water and in humid atmospheres, resulting in an almost uniform surface loss.

The water film permits electrolytic reactions to develop on the steel surface, leading to progressive corrosion. The rate of corrosion rapidly increases in the presence of other pollutants and raised humidity levels.

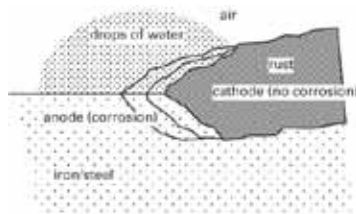

- **Galvanic corrosion (hydrogen type)**

Where two different metals of equal surface area are in contact in the presence of an electrolyte (moisture), an electrical current is formed and the less noble metal migrates and dissolves into the solution. Galvanic corrosion is also used for corrosion prevention where a less noble metal (anode) i.e. zinc, is used to protect the cathode, carbon steel. However, where the coating is damaged its protective effect diminishes. **Surface coatings on carbon steel fasteners are inevitably damaged during installation.**

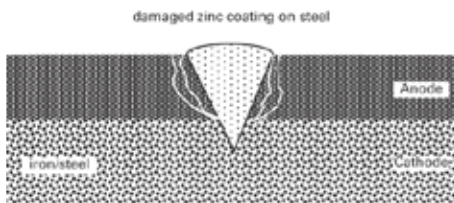

- **Biochemical corrosion**

Metals are dissolved in acids and caustic solutions of different strengths - this is called chemical corrosion, which develops because metals tend to combine with oxygen to form oxides. This tendency is all the stronger the less noble the metal. The acids that attack fasteners often come from the atmosphere, e.g. sulphuric acid, resulting from sulphur dioxide emissions from burning fossil fuels, is found in urban and industrial environments; nitric oxides, chlorine, hydrogen chloride, formic acid, acetic acid, etc., are found in the vicinity of corresponding industrial plants; chloride and sodium chloride in particular, are common atmospheric pollutants in coastal regions.

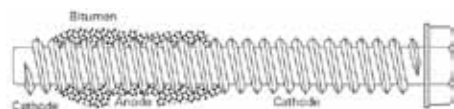

- **Aeration cell corrosion**

An oxygen deficiency can develop in damp thermal insulation, in laps of sheets where moisture is trapped and in other situations where moisture is trapped and pollutants can gather. The area of restricted oxygen supply becomes the anode and corrosion will result, even in non-polluted areas of high pH value. A lower pH value, i.e. where other pollutants are present, will increase the corrosion rate.

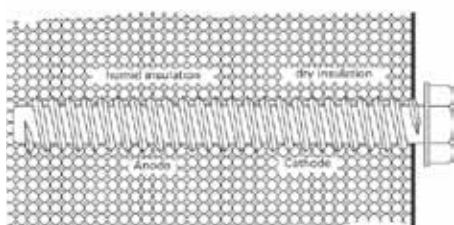

## 1.4 - Limitations of coated carbon steel



Coated carbon steel corrosion in a pitched roofing fastener

- Carbon steel rapidly corrodes upon exposure to humidity and polluted environments
- Surface coatings with excellent corrosion resistance can therefore be applied to prolong a fastener's life but they will only **slow down** the corrosion process
- The effectiveness of these coatings can only be gauged after considering the condition of the coating **once the fastener has been applied** within the construction
- These corrosion resistant coatings tend to have poor abrasion resistance
- Coatings on fasteners incorporated within all types of metal pitched roofing systems will inevitably be damaged during installation as the major portion of the shank penetrates the metal sheet and purlin.

### These pitched roofing systems include:-

- Composite - both factory and site-assembled
- Liner panel systems
- Liner tray systems
- "Secret fix" systems
- Single skin systems
- Over-roof systems



Coated carbon steel corrosion in a flat roofing fastener

**New flat roofing constructions (insulation and weatherproofing layer over a deck):** There is usually an insignificant risk of coating damage, however:

**Refurbishment and overlay:** There is a higher risk of damage to the coating as it passes through abrasive materials (chippings) within the original construction.

### Fasteners must have at least an equal life to the proposed roof system

- Coating damage reduces fastener life
- Corrosion leads to reduction in technical performance
- Corrosion leads to potential water ingress
- Corrosion leads to loss of aesthetic value of both the fastener and associated materials
- Coated carbon steel may be adequate for some less onerous applications, but consider what results from a subsequent change in building use to more aggressive internal conditions
- Corrosion of fasteners may lead to high consequential damage costs, high disruption costs and expensive remedial work

## Will coated carbon steel satisfy all your requirements?

## 1.5 - Types of stainless steel



SX austenitic stainless self-drilling fastener with *irius*® drive

“Rusting” is regarded by many as a process which is not applicable to stainless steel - this is however incorrect. “Stainless” steel is a generic term covering over 200 different types of alloy which all, to varying degrees, stain **less** than carbon steel. Stainless steels can be classified into three main groups:-

### Ferritic

- Contains at least 12% chromium
- Lower ductility than austenitic grades
- Cannot be hardened
- Susceptible to brittleness.

**Therefore, ferritic stainless is unsuitable for the manufacture of roofing and cladding fasteners**

### Martensitic (Typically AISI 410)

- Contains the minimum chromium content -11%
- Poor corrosion resistance
- Susceptible to stress corrosion
- Can be hardened (at the further expense of stress corrosion resistance)
- High thermal conductivity - as carbon steel
- Magnetic

**Therefore, martensitic stainless is not considered suitable for roofing and cladding fasteners**

### Austenitic (Typically AISI - 300 series)

- Contains at least 17% chromium
- Contains at least 8% nickel
- Molybdenum can also be added for extra corrosion resistance
- Non-hardenable \***Note 1**
- Non-magnetic \***Note 2**
- Low thermal conductivity, 25% of martensitic and carbon steel
- Best known grades are 304 and 316
- Excellent corrosion resistance \***Note 3**

**Therefore, austenitic is the *only* type of stainless steel recommended for roofing and cladding fasteners**

\* **Note 1:** The threadrolling process hardens the threads sufficiently to threadform but not enough for self drilling into steel purlins and rails. There are special techniques which incorporate a heat treated (hardened) carbon drillpoint to be joined to an austenitic stainless fastener to allow self drilling. It is vital that, once installed, all threads within and above the purlin line are austenitic stainless steel.

\* **Note 2:** Extreme cold forming of austenitic stainless steel wire can impart a small degree of residual magnetism without affecting the material properties.

\* **Note 3:** Some grades of austenitic are susceptible to chlorine induced stress corrosion cracking. Therefore, caution is required where the application is exposed to chlorine and condensation risk together with low pH values. Where these conditions present themselves, fasteners in this material should not be used in “safety-critical” applications i.e. where a failure may result in risk of personal injury. In such circumstances, it is unlikely that coated carbon steel fasteners would be less prone to failure due to their high corrosion potential.

## 1.5 - Other types of "stainless" fasteners



Corrosion of nitrided stainless

Austenitic is the only type of stainless steel recommended by British Standards for roofing and cladding fasteners. Because of the high technological investment required for the manufacture of austenitic self-drilling fasteners, alternative materials have been introduced by some distributors claiming a performance comparable to austenitic grades. Independent tests have highlighted fundamental weaknesses with these alternative stainless products:

### Nitrided stainless fasteners

There is a process available which hardens austenitic stainless steel fasteners sufficiently to enable them to self-drill mild steel without the need to incorporate a heat treated (hardened) carbon steel drillpoint. (Refer to Note 1 on the previous page).

This process results in chromium being withdrawn from the surface of the parent austenitic structure and therefore the base material loses its ability to form its passive protective layer and thus the fastener has reduced corrosion resistance.

To reinstate corrosion protection, the fasteners may then be coated with, typically, an organic material. It is this surface coating that provides the principal corrosion protection and (as described in Section 1.3, Limitations of coated carbon steel) the coating would inevitably be damaged during fastener installation and would, therefore, provide only **temporary** corrosion protection.



Corrosion of modified marstenitic

### Modified martensitic stainless fasteners

While martensitic grades of stainless steel fasteners with only 11% chromium are known to have poor corrosion resistance, their corrosion performance may be improved by modification of the material involving changing the element mix of their formulation and applying certain manufacturing techniques.

One such manufacturing technique involves hardening the surface of the fasteners to enable them to self-drill mild steel without the need for a hardened carbon steel drillpoint. The technique gives the fasteners a hard and smooth (polished) surface.

With production and installation limitations, a consistently high quality finish has been shown to be difficult to maintain and visible corrosion has been evident under accelerated Kesternich and Saltspray testing and also under normal weathering conditions. These fasteners are known to have a hard surface (550HV) and any surface corrosion can lead to the added risk of hydrogen-induced stress cracking and brittleness in such hard materials. The accelerated tests, such as Kesternich and saltspray, are not relevant to this type of corrosion.

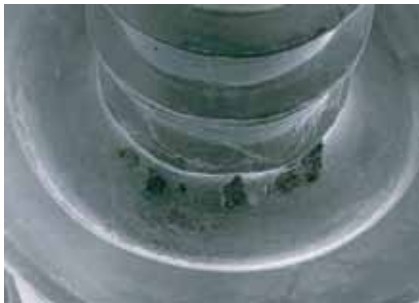

Crevice corrosion of modified marstenitic

Fasteners of such hard materials are not recommended for use in load-bearing applications in Japan.

Modified martensitic stainless steel fasteners are new to the world market and do not have the benefit of real life in-situ exposure over prolonged periods.

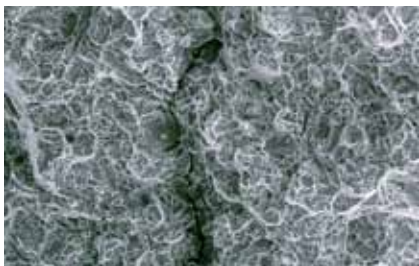

Stress corrosion cracking on modified marstenitic

**Austenitic stainless steel fasteners, such as grades 304 and 316, have been proven over a period exceeding 40 years in applications worldwide. Austenitic is the only type of stainless recommended.**

## 1.6 - Carbon or stainless? Selection considerations

---

In order that a designer or specifier can make the appropriate selection of fastener material, the following considerations must be addressed.

- 1.6 a) System materials**
- 1.6 b) Design life requirements**
- 1.6 c) External environment**
- 1.6 d) Internal environment (building use)**
- 1.6 e) Warranty requirements**

These considerations have been tabulated under section 1.7 to assist in fastener material selection

### 1.6.1 - System materials

---

In the selection of the fastener material in **pitched roofing and cladding systems**, compatibility with both the purlin and sheet material should be considered. Typical materials may include:

- Stainless steel
- Coated mild steel
- Aluminium
- Fibre cement
- Plastics (GRP, PVC, Polycarbonate)
- Timber

In **flat roofing systems** it is generally the compatibility with the deck material that has a direct influence on the fastener selection.

Decks are typically:

- Coated mild steel
- Aluminium
- Timber
- "Concrete"

#### Summary:

It is the industry practice always to use austenitic stainless steel fasteners in combination with aluminium and stainless steel system materials, i.e. sheets, decks and purlins.

Coated carbon steel fasteners could be considered when incorporated in conjunction with all the other system materials subject to their suitability relative to the remaining considerations 1.6 b), c), d) and e).

## 1.6.2 - Design life requirement

- What is the intended design life of the proposed building and individual components or assemblies as required and defined by the client (or his agent)?
- Refer to Tables 1 and 2 for expected performance of metal panels for guidance.

### Guide to: Durability of buildings and building elements, products and components.

Category	Description for category	Building life	Examples
1	Temporary	Agreed period up to 10 years.	Non-permanent site huts and temporary exhibition buildings.
2	Short Life	Minimum period 10 years.	Temporary classrooms; buildings for short life industrial processes; office internal refurbishment, retail and warehouse buildings: (see note 1).
3	Medium Life	Minimum period 30 years.	Most industrial buildings; housing refurbishment.
4	Normal Life	Minimum period 60 years.	New health and educational buildings; new housing and high quality refurbishment of public buildings.
5	Long Life	Minimum period 120 years.	Civic and other high quality buildings.

**Note 1.** Specific periods may be determined for particular buildings in any of categories 2 to 5, provided they do not exceed the period suggested for the next category below on the table; for example many retail and warehouse buildings are designed to have a service life of 20 years.

**Note 2.** Buildings may include replaceable and maintainable components (see Table 1.)

Category	Description	Life	Typical examples
1	Replaceable	Shorter life than the building life and replacement can be envisaged at design stage.	Most floor finishes and service installation components.
2	Maintainable	Will last with periodic treatment for the life of the building.	Most external claddings, doors and windows.
3	Lifelong	Will last for the life of the building.	Foundations and main structural elements.

## 1.6.2 - Design life requirement (continued)

---

Most industrial buildings to which these roofing and cladding systems are applied fall within the **medium life category** Table 1 minimum **30 years**.

- **Question 1: Can fasteners be classed as “replaceable” - Category 1 Table 2?**

Non exposed fasteners can only be accessed by removal of the external weathering sheet e.g. single ply membrane, liner panel and tray assemblies, secret fix systems.

In some cases the weathering sheet, once removed, would require total renewal rather than replacement.

Installing new fasteners, both exposed and non-exposed, into existing holes from which corroded fasteners have been taken would result in very much reduced pull-out values and security risk, unless an increased diameter fastener is used.

Composite panel fasteners have enlarged threads under the head to “support” the outer skin. As the sheet may have suffered damage and corrosion, simply installing a new fastener into the existing hole may not provide the required support, thus leading to a water ingress risk.

With some systems there would be other practical difficulties in removing and installing new fasteners.

**Answer 1: - NO, fasteners cannot be classed as “replaceable”.**

- **Question 2: Can fasteners be classed as “maintainable” - Category 2 Table 2?**

Internal fasteners cannot be maintained or “recoated” in situ.

Exposed fasteners may have their visible parts “recoated” but this should not be regarded as acceptable at the design stage of a project. Furthermore, applying a coating to the head, as well as being in most cases aesthetically unacceptable, would provide no additional protection to the concealed shank which may also be suffering from corrosion.

**Answer 2: - NO, fasteners cannot be classed as “maintainable”.**

**Fasteners for roofing and cladding systems must therefore be classed as LIFELONG (to the specified system) as defined in Table 2 - Category 3.**

### Summary:

Fasteners must have at least an equal service life to the particular system they are incorporated within.

Carbon steel fasteners should only be considered for buildings with a design life requirement conforming to Categories 1 and 2 of Table 1 and only limited buildings in Category 3 where a design life expectancy up to maximum of 30 years is required. All are subject to their suitability relative to the remaining considerations 1.6 a), c) and d).

Austenitic stainless steel fasteners should be the automatic choice for buildings with a design life in Categories 4 and 5 and a serious consideration for those in Category 3 where their design life exceeds 10/15 years.

### 1.6.3 - External environment

For example: The United States climate is classed as **warm temperate** with rain in all seasons. Buildings therefore are subjected to a wide range of atmospheric conditions which, in itself, presents onerous conditions for roofing and cladding systems in terms of resistance to wind, water ingress, U.V. and corrosion.

In addition to the climatic conditions present during each season, the local atmospheric conditions in the immediate vicinity of the building are more critical in the selection of a durable fastener material.

Typical atmospheres may be divided as follows:

• <b>Marine</b>	Up to 1-1/4 miles from the sea. High levels of chloride and sodium chloride.
• <b>Coastal</b>	Between 1-1/4 miles and 6-1/4 miles from the sea.
• <b>Industrial</b>	Atmosphere heavily polluted by sulphur dioxide and other pollutants, typically nitric oxides, chlorine, hydrogen chloride, formic acid, acetic acid, all in the vicinity of corresponding industrial plants.
• <b>Urban</b>	Densely populated area, polluted by sulphur dioxide.
• <b>Rural</b>	Mostly small towns and villages generally free from atmospheric pollution conducive to corrosion.

Note: Very often these different types of atmosphere overlap, thus presenting an even more aggressive external environment for both the cladding system and the fastener. For example, there are many marine and coastal areas which are densely industrialized.

#### Summary:

Clearly it is not easy to define precisely where coated carbon steel fasteners are suitable and where they are not. However, it is for certain that coated carbon steel fasteners **will** corrode when exposed to **any** of these atmospheres and the corrosion rate increases as you move up the table.

Austenitic stainless steel is durable in all these atmospheres and should always be specified in **marine** applications and would be, in many cases, the correct choice in most **coastal** and **industrial** atmospheres.

### 1.6.4 - Internal environment - (building use)



Leisure industry

In many applications where fasteners are incorporated within a roofing and cladding system, the internal environment (**building use**) is non-aggressive and, with the appropriate levels of insulation and vapor control, the build-up of moisture and pollutants within the system resulting from internal processes would be at such a low level so as not to present a corrosion risk to coated carbon steel fasteners.

However, some building uses and processes can, **and do**, present very aggressive conditions for the fastener. Therefore, **building use** is one of the primary considerations in order to determine the correct fastener choice between coated carbon and stainless steel.

Building uses which potentially present corrosive internal environments within the roofing and cladding system and therefore demand that austenitic stainless is specified, for both external and internal fasteners, include:

**Leisure industry:** Stadium roofs and cladding, Swimming pools, Sports centers

**Transport industry:** Airport buildings, Ferry buildings, Dockland buildings, Rail facilities, Canopies and covered walkways

**Water industry:** Sewage treatment works, Water treatment works, Pumping stations

**Power industry:** Flue gas desulphurization units (F.G.D.), Boiler houses, Aircool condenser buildings

**Manufacturing:** Paper, Pharmaceutical, Chemical/Petrochemical, Foundries, Brick, block and masonry products, Tobacco, Brewing, Textile, Food and drink



Transport industry

Typical building uses where coated carbon steel has been shown to perform adequately and can be considered where there is a design life expectancy requirement of up to a maximum of 30 years include:

**Retail**

**Distribution**

**Manufacturing:** Assembly, Windows and doors, Automotive, White goods, Metal processing



Manufacturing industry

There are some building uses which, even though the internal environment is non-aggressive, demand that austenitic stainless steel fasteners be considered. These include buildings where there are goods of very high value, buildings where hygiene is of paramount importance, and buildings which house sensitive equipment. Any water ingress due to fastener corrosion or failure would be very disruptive and it would be very expensive to repair or replace the goods or equipment.

Austenitic stainless fasteners should therefore be specified on buildings which house the following equipment;

**Electronics**  
**Hygiene**  
**High value goods**

**Computer equipment**  
**Food processing**

### Summary

The sections 1.1 - 1.6 of this guide have drawn to the attention of the designer and specifier the problems relating to fastener **durability** and explained all the detailed considerations that must be made in order that the correct fastener material can be specified.

The table below has been designed to assist the specifier in the selection of the most appropriate fastener material for each individual project.

## 1.7 - Guide to fastener material selection

Exposed fasteners - see note 2 for non-exposed fasteners

Fastener material	Environment		Functional life expectancy of fastener	Sheet/deck material ( see note 1 )			
	Internal	External		Aluminium	Coated steel	Stainless steel	GRP/PVC fibrecement
<b>Coated carbon steel with integral color head</b>	Dry/Low Humidity	Urban/Rural	10/20 15/25	<b>O</b>	✓	<b>O</b>	✓
		Industrial	15/20 15/20	<b>O</b>	<b>C</b>	<b>O</b>	<b>C</b>
		Coastal/Marine	-	<b>O</b>	<b>X</b>	<b>O</b>	<b>X</b>
	High Humidity	Urban/Rural	10/15	<b>O</b>	<b>C</b>	<b>O</b>	<b>C</b>
		Industrial	10	<b>O</b>	<b>C</b>	<b>O</b>	<b>C</b>
		Coastal/Marine	-	<b>O</b>	<b>X</b>	<b>O</b>	<b>X</b>
<b>Austenitic stainless steel</b>	All Conditions	Urban/Rural	30+	✓	✓	✓	✓
		Industrial	30+	✓	✓	✓	✓
		Coastal/Marine	30+	✓	✓	✓	✓
<b>Key</b>	Recommended		✓				
	Not recommended		<b>X</b>				
	Unsuitable		<b>O</b>				
	Check with manufacturer regarding suitability		<b>C</b>				

Note 1 - This table gives guidance on the selection and functional life expectancy of the **exposed fastener** in various sheet materials. Consult with the sheet manufacturer regarding the most appropriate sheet material and coating system and its functional life in the particular environment.

Note 2 - For carbon steel fasteners which are non-exposed to the external environment the functional life would be similar to those tabled above for carbon steel with integral color head.









## 1.8 - SFS intec austenitic stainless steel product range

Having identified the need for fasteners offering increased durability than that associated with coated carbon steel, SFS intec has developed a wide range of austenitic stainless steel fasteners to cover virtually all the roofing and cladding systems available worldwide.

The ranges indicated on this page (opposite), represents a selection of austenitic stainless steel fasteners from SFS intec appropriate to the principal roofing and cladding systems. There are many other types available and, for fasteners specific to your application detail, please contact SFS intec.

The SX range of self-drilling fasteners is manufactured from Grade 304 austenitic stainless steel and is designed for the various pitched roofing and cladding systems available.

The **isofast**<sup>®</sup> S range of fasteners is designed for flat roofing applications to secure insulation and weather-proofing membrane to decks and, in recognition of the potentially higher corrosion risk, is manufactured from Grade 316 austenitic stainless steel.

Washer if required				
	Roof	Wall		
SX3-L12	S19	S16	5,5xL	
SX6-L12	S19	S16	5,5xL	
SX14-L12	S19	S16	5,5xL	
SXW-L12	S16	S16	6,5x50	
SXL2-L12	S14	S14	5,5x22	
SX3-D12	--	--	5,5xL	
IR2-S	--	--	4,8xL	
SDK2-S	--	--	6,0xL	
TDB-S	S16	S16	6,3xL	

Corrosion resistant fasteners in austenitic chrome-nickel steels provide the only reliable way of fundamentally avoiding the corrosion problem.

## 2.1 - The problem

Exposed fasteners, i.e, those which penetrate the external weathering sheet, have to seal the penetration in the sheet for the design-life of the roofing and cladding system.

Exposed fasteners are therefore supplied with a sealing element or washer.

The design of the washer, and in some applications, the design of the fastener itself at the sheet interface, is therefore critical to ensure long-term performance compatible with the rest of the system. The total washer design must be resistant to the following:



Washer must seal hole in weather skin



Poor washer design

- Temperature range
- Water
- Acids
- Alkalis
- Ozone
- General weathering
- U.V. rays
- Aging
- Abrasion and splitting
- Overdriving
- Oblique and non perpendicular driving
- Pullover failure

## 2.2 - The SFS solution

SFS intec has considered all the various performance requirements of the washer, in conjunction with the fastener design relative to the particular type of roofing system, and has engineered washer systems to provide long-term security compatible with the fastener and the material being fastened.

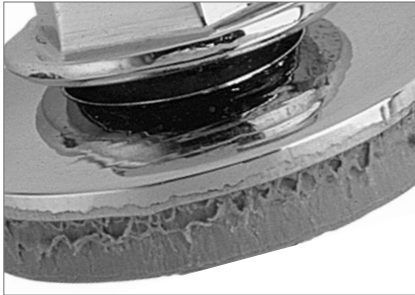

SFS intec vulcanized EPDM washers

### Sealing element

All SFS intec washers have an EPDM elastomer as the sealing element. An elastomer is a material which can be repeatedly stretched to at least twice its original length and will then return to its original length immediately when the tensile load is released. Due to its overall weathering resistance, EPDM (ethylene-propylene-diene-monomer) has become an established material within the fastener and building industry and has become an ideal substitute for neoprene whose weaknesses include resistance to general weathering, ultra-violet radiation, ozone, water, temperature as well as aging.

The thickness and hardness of the EPDM is designed relative to the fastener type and the washer diameter.

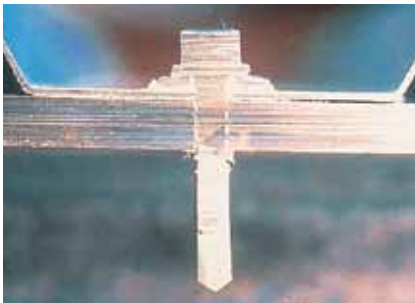

Total sealing with SFS washers

### Metal backing

To ensure the EPDM sealing element compresses evenly against both the flat sheet surface and the fastener shank, the EPDM is **vulcanized** to a metal backing washer. Merely glueing would risk the EPDM becoming detached as the fastener is tightened. A problem with loose sealing elements is clearly illustrated on the previous page where, for a number of reasons associated with inadequate fastener design, the sealing element has "compressed" beyond the head of the fastener and has been destroyed with the result that the seal will no longer be effective. This metal backing, which may be either galvanized steel, austenitic stainless steel, or aluminium, depending upon its durability requirements, is conically shaped and of a thickness such that it provides high resistance to overdriving and deformation.



washer Ø 3/4"



washer Ø 1/2" - 5/8"

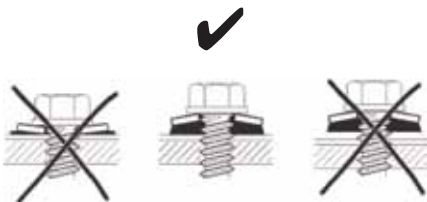

### Diameters

SFS intec sealing washers vary in diameter from, typically, 1/2" to 1-1/8". For primary valley fixing of metal roof profiles 3/4" is normally recommended. 1-1/8" washers are used for primary attaching of "plastic" rooflight profiles and the smaller diameters are normally recommended for the primary attaching of walling profiles and also most secondary applications such as sidelap stitching and flashings.

## 2.3 - Specialist fastener designs to ensure weathertightness

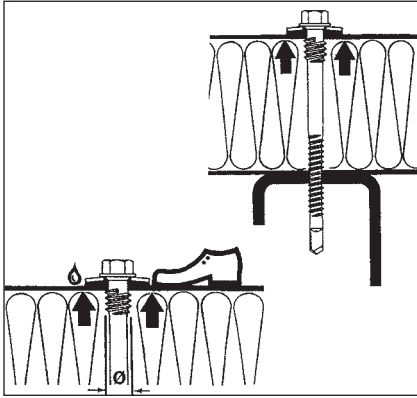

Sheet support and thread-free sections on SFS intec composite panel fasteners

### Composite panel fasteners

Trapezoidal metal profiles, in single skin form, or as part of a site assembled built-up (liner panel) system, are normally valley fixed to either the purlin or the spacer section, whichever is applicable. This is referred to as "direct" fixing, i.e. between the sheet and its support there is no compressible material which could, in service, become further compressed and thus break the seal. However, composite panels, by their very nature, have a non-rigid section (the insulation core) between their external skin and the purlin. Therefore, to provide long-term compression and sealing of the washer, composite panel fasteners are designed with a "dual" thread. The lower threads which drill and thread into the purlin are typically  $\text{Ø}12$  diameter (.197"). At the washer end of the fastener there is a secondary threaded section of an increased diameter, designed to engage in, and support, the outer skin of the panel, and thus provide permanent compression forces against the washer. The top thread should be designed so that it will continue to support the external skin against all positive applied loadings, including snow loads, and the concentrated dynamic load imparted by foot-traffic. With the appropriate safety factor, the top thread should therefore support a load of 1.26kN concentrated on the panel around the fastener. A test that could be adopted is defined in BS 5427: Part 1: 1996, Code of practice for: The use of profiled sheet for roof and wall cladding on buildings. Annex A, Clauses A.4.3 & A.5.c. To conform to this criteria all SFS intec composite panel fasteners have top threads of a minimum .275" diameter for steel facings.

SFS intec includes a further feature on these specialist fasteners. Immediately below and behind the washer there is a "thread-free" zone which ensures support, and therefore a long-term weathertight seal is given even when fasteners are overdriven, or in conditions where the fastener has to be further tightened in order to draw the panel and the purlin together.

## 2.3 - Specialist fastener designs to ensure weathertightness

---

### Stitching fasteners

Stitching fasteners are designed to clamp thin materials together (e.g. sidelaps of profiled metal sheets) and for fixing flashings and closures to profiled metal sheets and to themselves. Use of inappropriate fasteners may lead to threadstripping (overtorque) in which case, not only is weathertightness eliminated, but also the structural performance of the fastener is lost and components may become detached. Stitching fasteners, designed and manufactured by SFS intec, incorporate three main features to ensure structural performance and weathertightness;

**Reduced diameter drillpoint** - high pullout values.

**SFS intec washer** - thicker and softer than on primary fasteners to ensure a seal over a range of application thicknesses.

**Thread-free (free-spin) zone** - to draw and clamp the materials together and to eliminate any weathertightness risk associated with over-driving.

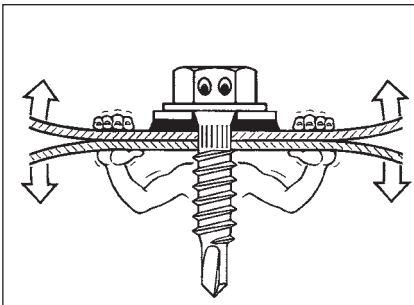

Thread free zone for weathertight clamping on SFS intec stitching fasteners

### 3.1 - The problem

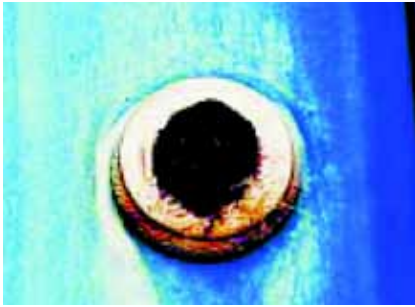

Moisture entrapment - accelerated corrosion leading to.....



.....rust staining on cladding.....



.....and roofing.

During the mid 1970s, the market share for color-coated cladding materials increased in the industrial building sector, and today color-coated cladding represents over 90% of the total market.

Color-coated materials are also used in cladding non-industrial buildings such as schools, hospitals, transport-related buildings, commercial buildings and high-rise accommodation.

The range of shapes to which these colored materials can be formed has given the architect much freedom of design, and great attention is paid to construction details and interfaces. Designers are also using color to create aesthetic appeal and impact to support their clients' corporate image.

Where visible fasteners are used to secure these colored materials it is, virtually without exception, desirable that the fastener head is permanently colored.

One attempt frequently chosen to obtain this color match is to simply push on a plastic color cap. However, there are many potential problems with this option:-

1. Caps missed off
2. Caps becoming dislodged
3. UV degradation
4. Color stability
5. Entrapment of moisture - corrosion staining
6. Short lifespan
7. Installation time

These are problems for both the contractor, who may have to make return visits to replace caps (snagging), and to the building owner who suffers a loss of aesthetic appeal and image and the expense associated with restoring the original finish.

### 3.2 - The SFS solution - Protecting your future



Because we all have a duty of care for the long-term performance of a roof, and because you need to be able to depend on the durability, quality, and performance of the fasteners that secure that roof, SFS has devoted considerable resources to developing a complete range of readily available "rust-free" fasteners, manufactured from austenitic stainless steel (300 series).

This is the only grade of stainless material recommended in BS 5427: 1996 for use in medium-life construction projects.

Due to the complex cold hardening process involved in the manufacture of these superior products, austenitic fasteners do cost more than carbon steel. However on a life-time costing basis this small cost is more than justified.

### 3.3 - Low-profile aesthetic head



SFS intec low profile, aesthetic heads

Where the designer selects a wall cladding profile for its high aesthetic appeal, he may also wish the fastening system to be virtually invisible and thus blend in with the cladding. Raised heads of fasteners, even though they may be factory-colored, may not always meet with the designer's criteria. In such cases, SFS intec can supply a range of low-profile headed primary and secondary fasteners which are available in the lacquered color form, and will blend in with the cladding to provide an unobtrusive and pleasing aesthetic appearance.

At all SFS intec factories services in Europe, and North America, fasteners can be painted to provide a stable, resistant and permanent color match offering higher performance than that normally associated with a wet cellulose based coating.

### 3.4 - Aesthetics with security: *irius*<sup>®</sup> drive system



Innovative *irius*<sup>®</sup> drive system

SFS intec has introduced a new range of low-profile aesthetic headed lacquered products which has an innovative *irius*<sup>®</sup> drive system. The visible surface of the low-profile head is smooth unlike other conventional internal drive products which have Torx, Phillips or Pozi recesses. To enable the fastener to be driven, there are concealed "teeth" to the underside of the low-profile head onto which the specially configured socket engages. As well as providing an unobtrusive aesthetic appearance, this new headform also offers the specifier and client high levels of tamper-resistance and security.

## 4.1 - Structural performance

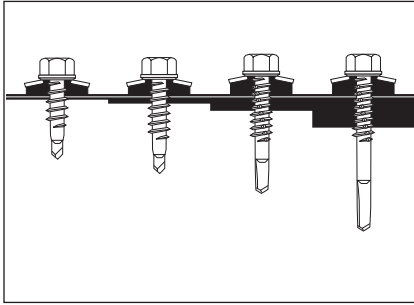

SD and SX drillpoints are designed to give optimum pullout resistance and security

Apart from **durability, weathertightness** and **aesthetics**, a fastener has to be capable of withstanding a range of types of loading. The types of loading are specific to the particular systems and therefore fasteners are designed such as to give optimum performance compatible with the requirements of the system itself.

Typical structural performance criteria which influence fastener design include:

- |                                    |                                      |
|------------------------------------|--------------------------------------|
| 4.2 Pullout and tensile resistance | 4.7 Unwinding                        |
| 4.3 Pullover resistance            | 4.8 Clamping of the membrane         |
| 4.4 Dynamic bend resistance        | 4.9 Over torque                      |
| 4.5 Pushdown resistance            | 4.10 Fastener frequency calculations |
| 4.6 Shear resistance               | 4.11 Material compatibility          |
|                                    | 4.12 Tooling systems                 |

## 4.2 - Pullout and tensile resistance

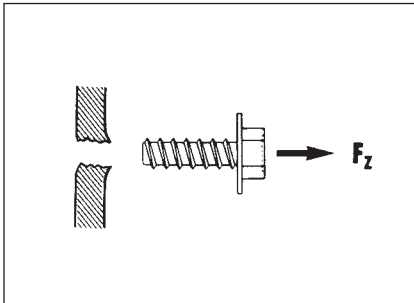

Failure of sheet through pullout

This is the ability of a fastener's threaded connection to remain intact and resist axial and tensile loadings.

**Self-tapping fasteners** require a pilot hole to be pre-drilled prior to installation into the steel (or aluminium) supporting section. The pullout resistance will be directly related to the pilot hole diameter actually drilled. Specific thicknesses of support require specific pilot hole diameters, with the diameter increasing as the thickness of support increases. If too large a hole is drilled in a particular support thickness then the pullout value is reduced, and the risk of overtorque is increased. If too small a hole is drilled, then the fastener will require higher torque to enable installation. This increased torque may lead to reduced tensile performance of the fastener. Self-tapping fasteners are therefore entirely dependant on the operative selecting the correct drill diameter, using a quality non-worn drill, and pre-drilling without wobble, so that the pullout values can be consistently achieved.

Additionally, self-tapping fasteners are relatively slow to install due to the dual operation and the need for two tools. This may therefore increase the duration (and cost) of construction programs because a longer period of time will be required before the roof is made weather-tight and following trades are able to continue under cover.

**Self-drilling fasteners** have been developed and are available for the majority of applications into metal thicknesses up to .55". This type of fastener is manufactured with its own integral drillpoint which is engineered to drill and facilitate efficient threadforming into pre-determined metal thicknesses, resulting in optimum pullout values with none of the risks associated with self-tappers. SFS intec designates self-drillers with a reference to the drilling capacity, to assist designers and contractors in the correct selection, e.g. SX3..., SX6..., SX14.... These fasteners have purpose-designed drillpoints and thread types to enable their use within metals of up to .12", .24" and .55" respectively. It can be seen from the diagram opposite that the drillpoint increases in both diameter and length as the support thickness increases.

### 4.3 - Pullover resistance

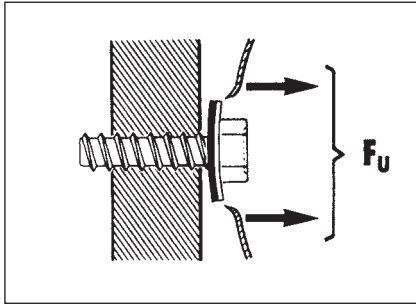

This is the ability of the fastener to prevent the sheet material failing by pulling over the head of the fastener - see illustration opposite.

As stated within the preceding Section 2 on "Weathertightness," resistance to pullover failure of the sheet is related to the strength and diameter of the WRS washer.

The illustration not only gives an indication of the high pullout values of SFS self-drillers, but also shows the extremely high resistance of the Sela molded headform to pullover.

Failure of sheet through pullover

### 4.4 - Dynamic bend resistance



Long fasteners used to secure composite panels and also fibre cement sheets i.e. where the head is spaced off the support, tend to be subjected to bending forces. In the case of composites, these bending forces tend to be dynamic and repetitive. The forces are generated by the deflections and thermal movements of the panels and bending of the fastener is generally greater in hot-rolled support sections, which tend to be less flexible, than in thinner cold-rolled sections. There is an industry test method for such fasteners defined in the European Convention for Constructional Steelwork (ECCS) Document No66, Preliminary European Recommendations for Sandwich Panels, Part 1 - Design, and manufacturers of composite panel fasteners are therefore required to accommodate these bending forces within their designs and demonstrate compliance with the tests. All SFS intec composite panel fasteners, SXC and SDT product groups, comply with these requirements.

ECCS repetitive bending tests on SFS intec composite panel fasteners

### 4.5 - Pushdown resistance

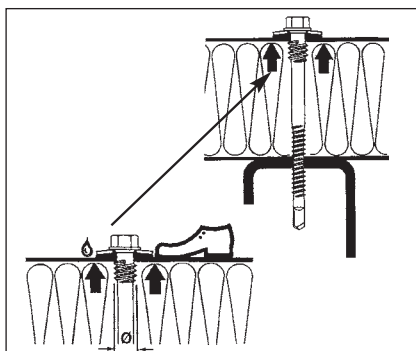

As described with Section 2 on "Weathertightness," composite panel fasteners have a secondary thread of increased diameter immediately under the washer. This thread must be designed to resist the concentrated loadings as defined in BS 5427: Part 1: 1996 Code of practice for the use of profiled sheet for roof and wall cladding on buildings, Annex A Clauses A.4.3.& A.5.c. The SFS intec SXC and SDT product groups for composite panel fasteners meet these loading requirements as well as providing the additional weatherability performance offered by the thread-free zone.

Sheet support and thread-free sections on SFS composite panel fasteners

## 4.6 - Shear resistance

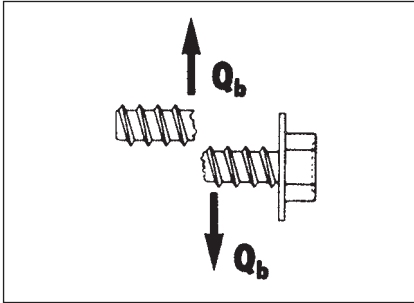

SFS intec *isofast*<sup>®</sup> drillpoint and threadform

In some applications fasteners are subjected to a direct shear loading. SFS intec publishes documentation which gives the ultimate shear failure value of the fastener and shows, where applicable, the loading at which the materials being fastened are displaced by 1/8".

## 4.7 - Unwinding

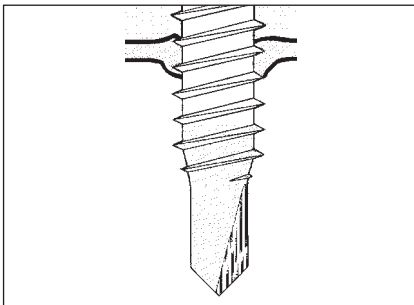

SFS intec *isofast*<sup>®</sup> drillpoint and threadform

This phenomenon is not normally associated with pitched roofing systems, but has to be "designed out" on fasteners for securing single-ply coverings over metal decks.

As the wind passes over the flexible membrane an eccentric force passes through the fastener. The SFS intec *isofast*<sup>®</sup> system is able to accommodate these dynamic windloads by nature of its "reduced" diameter drillpoint, the tapered lead-in thread section and its shallow thread pitch angle. These features combine to give total thread engagement within the deck and to also provide the optimum pullout from "thin", .025" minimum, steel decks.

## 4.8 - Clamping of the membrane



SFS intec *isofast*<sup>®</sup> system for high clamping of membranes

On seam-fastened single-ply membranes, the washer or stress plate is designed to resist any sideways movement of the membrane which could ultimately lead to tearing of the membrane, followed by failure. SFS intec can offer a variety of stress plate designs which, because of their high clamping qualities, may allow a 25% increase in fastener safe working loads in membranes which are classed as "reinforced". Advice should be sought from the particular membrane supplier to ensure the proposed fastening system and its permissible loadings are appropriate to their membrane.

## 4.9 - Over torque

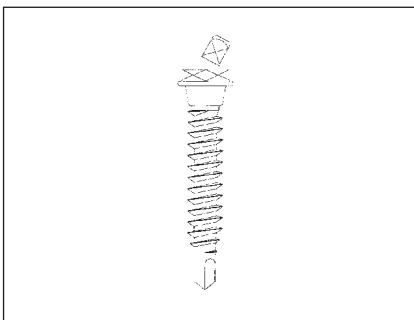

SDK fastener principal to prevent over-torque

Overdriving of fasteners may lead to thread stripping within cold-rolled sections and either thread stripping or heads shearing off the fasteners in hot-rolled sections. Control in driving, and thus the prevention of overtorque, lies firmly within the control of the installer. Screwguns should **always** be fitted with correctly set depth-locators. Furthermore, SFS intec can supply attachments for screwguns which can ensure correct and consistent setting, as well as increasing the speed of installation. Section 4.10 below illustrates a selection of the tooling systems available from SFS intec.

Recognizing the greater risk of overdriving when fastening into thin materials, SFS intec has developed a new concept in fastening, illustrated opposite, to ensure the operative cannot overtorque the fastener.



IF30



IF240



CF40

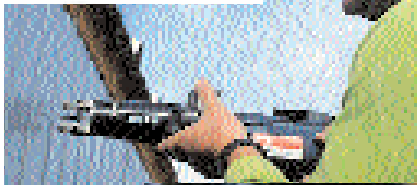

CF55



CF400



CF400

## 4.10 - Fastener frequency calculations

SFS intec publishes a wide range of technical performance data on its fasteners. Generally the values given are the ultimate values. The engineer would then apply a safety factor appropriate to the particular countries regulations/standards.

To determine the actual frequency of fasteners, it is necessary that all loading criteria are made available to include windloads.

With this information available, SFS intec can work in close co-operation with the designer, the system supplier, and the contractor to assist in determining fastener frequencies.

## 4.11 - Material compatibility

The risk for bi-metallic corrosion between components of different metals should be assessed by the Designer.

Commentary on corrosion at bimetallic contacts and its alleviation, may be referred to in order that any risk could be assessed. Consideration must be made to the relative surface areas of the metals in contact. To prevent bi-metallic corrosion at the connection, the fastener should be of a material with, at least, the equivalent corrosion resistance to the material being fastened into/through. For these reasons austenitic stainless fasteners securing steel or aluminium profiles to galvanized steel support sections are considered a suitable combination, whereas carbon steel fasteners are not considered suitable for securing aluminium sheeting. Perhaps the main risk within metal cladding systems occurs where aluminium profiles are in contact with galvanized steel spacers or supports. It is recommended practice, therefore, in these conditions to apply a separation layer, usually an adhesive tape, over the whole surface of the support component in contact with the aluminium.

## 4.12 - Tooling systems

As noted in 4.8 on the previous page, the risk of overdriving fasteners can be eliminated by always ensuring screwguns are fitted with correctly set depth locators. SFS intec has taken this one step further by developing fastening systems which include purpose-designed tooling specifically developed for fasteners for the various roofing and cladding assemblies. These systems help to provide security for the client as well as assisting the contractor in terms of both speed and consistent installation.

**Tooling systems include;**

- IF30** - Semi-automatic system for insulation and membrane to metal
- IF240** - decks
- CF40** - Semi-automatic system for fibre cement
- CF55** - Semi-automatic system for composite panels
- CF400** - Fully-automatic system for metal sheeting, decking and side laps

## 5.1 - Below are summarized the solutions to the four principal functions

---

We hope this Guide demonstrates the importance of the appropriate specification and selection of one of the smallest, if not **the** smallest, component within the roofing and cladding system.

In the preceding sections, the four principal functions of fasteners have been discussed in detail to enable the designer and specifier to consider all the aspects of a project, so that the selection of fasteners can be made appropriate to the demands relative to the individual project.

### Durability

- Stainless steel - austenitic, typically of Grade 304 or 316
- All threads within and above the supports must be austenitic stainless steel

### Weathertightness

- EPDM elastomer washer
- Vulcanized (permanently bonded) to a metal backing
- Support threads on composite panel fasteners
- Thread-free zones on composite panel fasteners and stitchers

### Aesthetics

- Lacquered coated
- Low profile headform (*irius*<sup>®</sup>)

### Structural

- Co-ordinated design
- Technical documentation
- Third party and industry approvals
- Specialist tooling systems
- Quality assured manufacturing source

## 5.2 - Model specification sheets

To assist the specifier, SFS intec specification advisors prepare project-related specifications which may then be incorporated within the tender documentation. Such specifications may be provided in a format complying with that adopted by the particular practice, for example, either prescriptive, performance or a specification format appropriate to the particular country.



### 5.3 - Specification support information

---



#### **Security and quality through planning**

Every project is different, and with the increasing number of fastener products on the market, and ever more pressure on your time, just how do you sift through the mass of information available to specify the correct fastener?

The answer is to let SFS intec help. Our technical team is geared up to working with architects, designers, structural engineers and contractors to provide informed, detailed and reliable specification guidance, right from the planning stages of a project through to completion. And with our technical phone helpline, getting expert advice is now even quicker and easier than ever before.



#### **Advisory service for engineers and architects**

During the design phase of a building, complex and sometimes conflicting requirements can place diverse demands on the fastener. SFS intec experienced technical team can help you to resolve fastener issues during the design stages, working side-by-side with architects and engineers to ensure that performance requirements are met and the project proceeds without a hitch.

#### **Taking our cue from your needs**

Creating a building is about forging effective partnerships. When working on a project you need to select a fastener supplier who is not only an expert in the field, but who can also take an overview of the project, understand your requirements, and work with you to solve specific problems. Through our network of technical advisors, SFS intec maintains a close partnership with architects, engineers and contractors on building projects worldwide, helping us to stay in touch with your commercial needs. This essential dialogue between us and the end-users of our products has triggered many new ideas for fastening systems that solve the problems you commonly encounter.

### 5.3 - Specification support information



#### Meeting the expectations of a competitive market

As everyone in the building industry knows, building regulations and techniques are constantly changing, and architects, designers and contractors alike are having to respond to new demands with regard to safety, energy efficiency, durability and aesthetics. SFS intec is represented on the technical committees of industry bodies, so we can ensure fastener specifications are able to comply with these changes. We also work in partnership with the leading system suppliers, architectural and engineering practices, and an ever-expanding network of roofing contractors, so that we are able to pre-empt the changing needs of the industry. Our continuous investment in research and development ensures that we are at the forefront of developing new solutions to meet changing requirements.



#### Long-term partnerships with roofing system suppliers

Leading roofing and cladding system manufacturers, are constantly improving and developing their products and SFS intec is matching these developments with new fastener technologies. Worldwide, SFS intec technical specialists are working in partnership with the leading system manufacturers in roofing and cladding to bring competitive, high-performance fastener solutions to the market. SFS intec products are endorsed, sometimes exclusively, by many suppliers - testimony to our commitment to a partnership approach, and the creation of practical, customized solutions for today's competitive market.



#### Innovative solutions to benefit everyone - from architect through to client

As building design moves forward, architects, engineers, and contractors face new challenges and new problems which must be met with innovative product solutions. At SFS intec we aim to meet and exceed your expectations of product performance through constant research and development into practical, effective fasteners and fastening systems. Through our close relationship with test houses, research laboratories and manufacturers of roofing and cladding systems, plus our own research, metallurgy, drill technology and corrosion testing facilities, we are able to bring you the most technologically advanced solutions to today's fastening needs.

Examples include:

- Purpose-designed austenitic stainless steel self-drilling fasteners
- Factory-colored fasteners
- New concept fasteners for "thin" metal materials
- Automatic fastening tooling systems

### 5.3 - Specification support information



#### **Adding value to the project the SFS intec quality guarantee**

In this competitive market, clients are always looking for added value, whether it means a higher level of specification, greater longevity of the building, low maintenance or improved performance. Creating that added value means being able to rely on even the smallest components in the building to support the demand for overall quality.

Recognized worldwide for its commitment to the highest standards of product performance and customer service, SFS intec products and systems can play an important part in helping you to deliver customer satisfaction.

Throughout the SFS intec organization, specialized on-going training ensures that you benefit from an informed, technically aware and experienced team, at all levels. In terms of production, SFS intec exacting quality assurance system exceeds international requirements, so you can have complete confidence in the technical values and performance specifications of the products you specify and use.



#### **Training and on-site installation**

Precision during installation can be the difference between a secure roof or performance problems. To help you eliminate any risk, SFS intec offers free training in the use of SFS intec on-site fastener installation tools. These semi and fully automated purpose designed tooling systems are available to ensure every fastener is consistently and securely installed in an ergonomic and economic manner. Whether you require one of our technical team to carry out training on site, or you prefer to visit the technical training center, our expertise is only a phone-call away.

## 5.3a - Internet - welcome to SFS intec

### Dialogue and contact around-the-clock!



#### [www.sfsintec.biz](http://www.sfsintec.biz)

Continuous information exchange with our customers has been a cornerstone to the continuous development of our products and services we have maintained over the years.

Alongside the day-to-day contact on the part of our local customer support staff, the internet represents an additional platform for dialogue with our global partners. We want to support your daily work by keeping you constantly abreast of market and product-specific information through our home page.

#### Our Market Organizations:

Czech Republic  
Estonia  
Finland  
France  
Germany  
Great Britain

[www.sfsintec.biz/cz](http://www.sfsintec.biz/cz)  
[www.sfsintec.biz/ee](http://www.sfsintec.biz/ee)  
[www.sfsintec.biz/fi](http://www.sfsintec.biz/fi)  
[www.sfsintec.biz/fr](http://www.sfsintec.biz/fr)  
[www.sfsintec.biz/de](http://www.sfsintec.biz/de)  
[www.sfsintec.biz/uk](http://www.sfsintec.biz/uk)

Hungary  
Italy  
Norway  
Poland  
Spain  
Sweden  
USA

[www.sfsintec.biz/hu](http://www.sfsintec.biz/hu)  
[www.sfsintec.biz/it](http://www.sfsintec.biz/it)  
[www.sfsintec.biz/no](http://www.sfsintec.biz/no)  
[www.sfsintec.biz/pl](http://www.sfsintec.biz/pl)  
[www.sfsintec.biz/es](http://www.sfsintec.biz/es)  
[www.sfsintec.biz/se](http://www.sfsintec.biz/se)  
[www.sfsintecusa.com](http://www.sfsintecusa.com)

**Project name:** Roissy Charles de Gaulle Airport - Terminal 2E

**Building use:** Airport



<b>Size</b>	645,835 sq. ft
<b>Construction year</b>	2001-2002
<b>Country / Building location</b>	France - Roissy
<b>Flat roofing systems</b>	Deck stainless steel sheet
<b>SFS Products</b>	IR2-S-4,8x100, ID-70x70, SN3/18-7982-SR2-4,2x25
<b>Architect</b>	Aéroport de Paris - ADP Paul Andreu , Jean Michel Fourcade - ADP ingénierie
<b>Main Contractor HB</b>	UTB - Pantin (93)

**Project name:** Original Teile Center Volkswagen

**Building use:** Distribution Center



<b>Size:</b>	1,184,030 sq. ft. Flatroof, 193,750 sq. ft. wall (Facade)
<b>Construction year</b>	2005
<b>Country / Building location</b>	Baunatal / Gladbeck / Deutschland
<b>Roofing systems</b>	PVC Membrane, Rockwool mineral insulation
<b>SFS Products Flat Roof</b>	IR2-m- incl. IR82x40
<b>SFS Products Cladding</b>	SX3, SX6, SL2
<b>Client</b>	Volkswagen VW
<b>Architect</b>	RSE, Kassel
<b>Main Contracto:</b>	Elite, Neu-Ulm

**Project name:** Airbus A380 - Usine Jean Luc Lagardère

**Building use:** Planes construction



<b>Size</b>	1,291,669 sq. ft.
<b>Construction year</b>	2002 - 2004
<b>Country / Building location</b>	Toulouse Blagnac - France
<b>Roofing / Cladding systems</b>	Bituminous flatroof / Metal cladding / Stainless steel metal doors
<b>SFS Products</b>	SFS <i>irius</i> ® SD5 colored / SFS <i>irius</i> ® SX3
<b>Client</b>	Airbus France
<b>Architect</b>	ADP - Aéroport de Paris, Cardete et Huet - Toulouse
<b>Sub Contractor</b>	Smac Acieroid Toulouse, Soprema Toulouse, Acieroid Espagne

## Project Referral

**Project name:** Chrysler-Jeep

**Building use:** Automotive Plant



<b>Size</b>	1,200,176 sq. ft.
<b>Construction year</b>	1999
<b>Country / Building location</b>	USA / Toledo, Ohio
<b>Flat roofing systems</b>	Johns Manville 60-mil PVC
<b>SFS Products</b>	IF2-M-4,8x60, IF2-M-6,7x76, IF/IG-70x70, IF-2.375-AT,
<b>Client</b>	Daimler-Chrysler
<b>Main Contractor</b>	Fred Christen & Sons, Inc.

## Project Referral

**Project name:** IKEA stores  
**Building use:** Distribution Center



<b>Size</b>	753,474 sq. ft.
<b>Construction year</b>	2005
<b>Country / Building location</b>	Doncaster England
<b>Flat roofing system</b>	Sarnafil T Membrane, Rockwool mineral insulation
<b>SFS intec Products</b>	Fastener: SBF-SQ3, TI-Z10 Tube: SFT (Sarnafast) Tool: TP10, 19 and 30
<b>Main contractor</b>	Shepherd Construction
<b>Roofing contractor</b>	Roofdec Ltd.

**Project name:** City Hall, Praha

**Building use:** Sport, Culture, Entertainment



<b>Size</b>	279,862 sq. ft.
<b>Construction year</b>	1999
<b>Country / Building location</b>	Czech Republic, Praha
<b>Roofing / Cladding systems</b>	Rheinzink, Sandwichpanels DART
<b>Flat roofing systems</b>	Steel-deck
<b>SFS Products</b>	SX, SD, SW-S
<b>Client</b>	Municipality of Praha
<b>Main Contractor</b>	Izolprag

## Project Referral

**Project name:** Government Communications Headquarter (GCHQ)  
**Building use:** Administration



<b>Size</b>	129,167 sq. ft.
<b>Construction year</b>	2003
<b>Country / Building location</b>	England / Cheltenham
<b>Roofing / Cladding systems</b>	Prater Roofing, Corus Building, Kalzip system
<b>SFS Products</b>	SX <i>irius</i> ®, SD3, bulbtite rivets
<b>Client</b>	Government

## Project Referral

**Project name:** Taipei Financial Center, Zone 4

**Building use:** Financial Center 101



<b>Size</b>	1,640 ft. Height
<b>Construction year</b>	2002
<b>Country / Building location</b>	Taipei
<b>SFS intec Products</b>	TDB, TDC, SX3, SX6, SN3, SN5, SN 6 about 2,3 Million pcs.
<b>Architect</b>	C Y Lee & Partners
<b>Main contractor</b>	Josef Gartner & Co (HK) Ltd.





© SFS intec, iRC, 01/08, 901932, USA  
Technical changes reserved  
Printed in Switzerland

---

#### Technical advice and sales service

SFS intec, Inc.  
FasteningSystems  
Spring Street & Van Reed Road,  
P.O. Box 6326  
Wyomissing, PA 19610

800 234 4533  
T 610 376 5751  
F 610 376 8551  
[www.sfsintecusa.com](http://www.sfsintecusa.com)  
[us.wysales@sfsintec.biz](mailto:us.wysales@sfsintec.biz)

**SFS** intec  
Turn ideas into reality.